



...eine starke Verbindung

DECLARATION OF PERFORMANCE

DoP Nr.: **MKT-1.5-200_en**

- ✧ **Unique identification code of product-type:** **Ceiling Anchor DN**
- ✧ **Intended use/es:** Fastener for use in concrete for redundant non-structural systems, see Annex B
- ✧ **Manufacturer:** MKT Metall-Kunststoff-Technik GmbH & Co.KG
Auf dem Immel 2
67685 Weilerbach
- ✧ **System/s of AVCP:** 2+
- ✧ **European Assessment Document:** **EAD 330747-00-0601**
European Technical Assessment: **ETA-23/0246, 04.07.2023**
Technical Assessment Body: DIBt, Berlin
Notified body/ies: NB 2323 – IEA GmbH & Co.KG, Stuttgart

✧ **Declared performance/s:**

Essential characteristics	Performance
Safety in case of fire (BWR 2)	
Reaction to fire	Class A1
Resistance to fire	Annex C1
Safety in use (BWR 4)	
Characteristic resistance for all load directions and modes of failure for simplified design	Annex C1
Durability	Annex B1

The performance of the product identified above is in conformity with the set of declared performance/s. This declaration of performance is issued, in accordance with Regulation (EU) No 305/2011, under the sole responsibility of the manufacturer identified above.

Signed for and on behalf of the manufacturer by:

Stefan Weustenhagen
(General manager)

Weilerbach, 04.07.2023

p.p. 
Dipl.-Ing. Detlef Bigalke
(Head of product development)



The original of this declaration of performance was written in German. In the event of deviations in the translation, the German version shall be valid.

Specifications of intended use

Ceiling Anchor	DN 6x40	DN 6x70
Use only for redundant non-structural systems acc. to EN 1992-4:2018		
Static and quasi-static actions	✓	
Fire exposure	R30 to R120	
Base materials	compacted, reinforced or unreinforced normal weight concrete without fibres acc. to EN 206:2013 + A1:2016	
Strength classes	C20/25 to C50/60 acc. to EN 206:2013 + A1:2016	
Cracked and uncracked concrete	✓	

Use conditions (Environmental conditions):

- Structures subject to dry internal conditions

Design:

- Anchorages are designed under the responsibility of an engineer experienced in anchorages and concrete work
- Verifiable calculation notes and drawings are prepared taking account of the loads to be anchored. The position of the anchor is indicated on the design drawings (e.g. position of the anchor relative to reinforcement or to supports, etc.)
- Anchorages are designed according to EN 1992-4:2018, Annex G, Method C

Installation:

- Hole drilling by hammer drill bit or hollow drill bit
- Anchor installation carried out by appropriately qualified personal and under supervision of the person responsible for technical matters of the site
- Positioning of the drill holes without damaging the reinforcement
- Overhead installation is permitted

Ceiling Anchor DN	Annex B1
Intended use Specifications	

Table B1: Installation parameters

Ceiling Anchor			DN 6x40	DN 6x70
Nominal drill hole diameter	d_0	[mm]	6,0	
Cutting diameter of drill bit	$d_{cut} \leq$	[mm]	6,4	
Depth of drill hole	$h_0 \geq$	[mm]	40	
Effective anchorage depth	$h_{ef} \geq$	[mm]	32	
Diameter of clearance hole in the fixture	$d_f \leq$	[mm]	7	
Thickness of fixture	$t_{fix} \leq$	[mm]	5	35
Minimum thickness of member	h_{min}	[mm]	80	
Minimum edge distance	c_{min}	[mm]	150	
Minimum spacing	s_{min}	[mm]	200	

DN 6x40

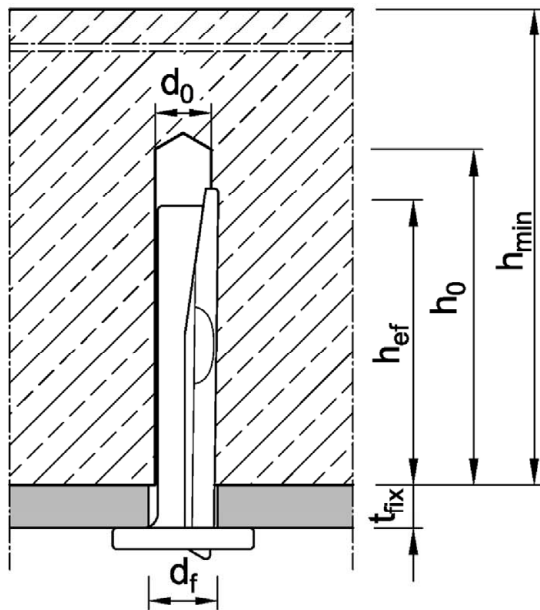

DN 6x70

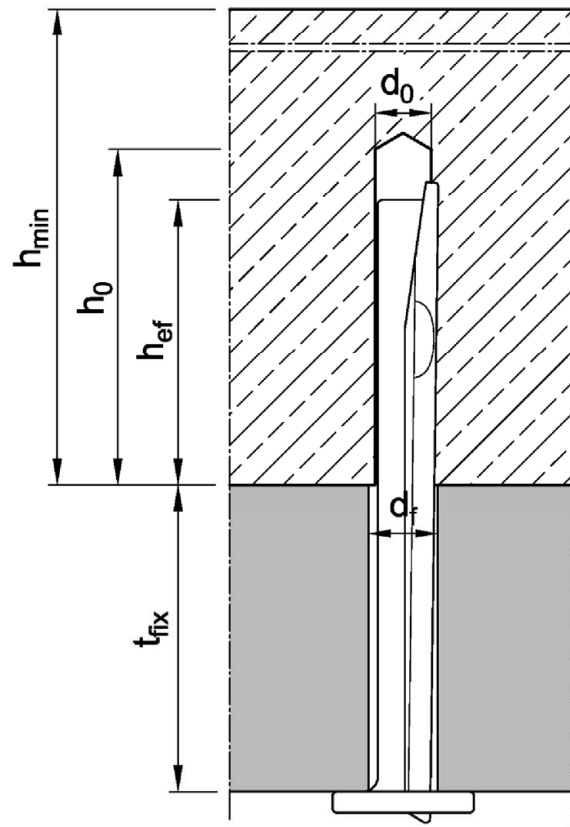

Ceiling Anchor DN

Intended use
Installation parameters

Annex B2

Installation instructions

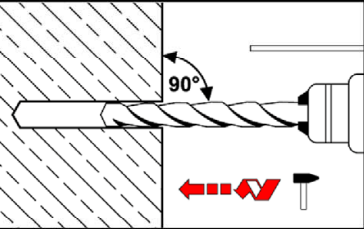
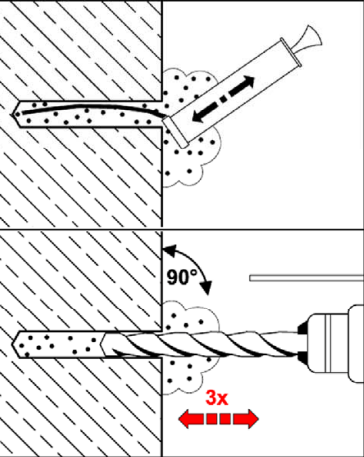
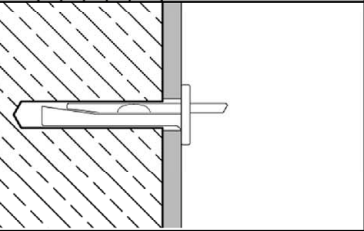
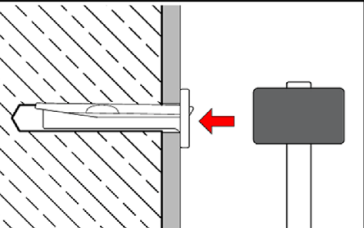
1		<p>Drill hole perpendicular to concrete surface.</p>
2		<p>Blow out dust. Alternatively, vacuum clean down to the bottom of the hole.</p> <p>or</p> <p>When reaching the drill hole depth pull out the drill bit whilst power drill is switched on. To reduce the drill dust in the drill hole repeat this step minimum three times, starting from the bottom of the borehole (discharging the drill hole).</p>
3		<p>Insert Ceiling Anchor up to attachment contact.</p>
4		<p>Drive in the protruding pin.</p>

<p>Ceiling Anchor DN</p>	<p>Annex B3</p>
<p>Intended use Installation instructions</p>	

Table C1: Characteristic values for all load directions and failure modes

Ceiling Anchor			DN 6x40	DN 6x70
Installation factor	γ_{inst}	[-]	1,0	
All load directions and for all failures				
Characteristic resistance in cracked and uncracked concrete C20/25 to C50/60	F_{Rk}	[kN]	5,0	
Partial factor ¹⁾	γ_M	[-]	1,5	
Minimum edge distance	$c_{cr} = c_{min}$	[mm]	150	
Minimum spacing	$s_{cr} = s_{min}$	[mm]	200	
Steel failure with lever arm				
Characteristic bending resistance	$M^0_{Rk,s}$	[Nm]	5,1	
Partial factor ¹⁾	γ_{Ms}	[-]	1,25	

¹⁾ In absence of other national regulations

Table C2: Characteristic values under fire exposure

Ceiling Anchor			DN 6x40	DN 6x70	
all load directions					
Fire resistance class	R30	Characteristic resistance	$F_{Rk,fi}$	[kN]	0,74
	R60		$F_{Rk,fi}$	[kN]	0,61
	R90		$F_{Rk,fi}$	[kN]	0,49
	R120		$F_{Rk,fi}$	[kN]	0,42
Steel failure with lever arm					
Fire resistance class	R30	Characteristic bending resistance	$M^0_{Rk,s,fi}$	[Nm]	0,39
	R60		$M^0_{Rk,s,fi}$	[Nm]	0,33
	R90		$M^0_{Rk,s,fi}$	[Nm]	0,26
	R120		$M^0_{Rk,s,fi}$	[Nm]	0,23
Edge distance and spacing, partial factor					
Fire resistance class	R30 to R120	Partial factor	$\gamma_{M,fi}$	[-]	1,0
		Spacing	$s_{cr,fi}$	[mm]	200
		Edge distance	$c_{cr,fi}$	[mm]	150
For fire exposure from more than one side $c \geq 300mm$.					

Ceiling Anchor DN

Performance
Characteristic resistance

Annex C1